



ULTRAFLOW

Indirect Pre-Plumbed

PRE-PLUMB ADDENDUM

INSTALLATION MANUAL V2 2021

IMPORTANT

This range of water heaters and unvented water storage cylinders should only be installed as per these instructions by a competent & certified heating installer. By installing this product you agree to be bound by the purchasing and warranty terms and conditions found in this manual and on our website.



Introduction

These supplementary instructions are designed to be read in conjunction with the main product installation manual. Particular attention should be paid to all the relevant legislative requirements, including Building Regulations, Water Regulations, IEE Wiring requirements and general good practice. The installation shall only be conducted by a person competent to do so.

This UK pre-plumbed cylinder is a standard unvented hot water storage cylinder with central heating components assembled and mounted onto the front of the casing.

In addition to the components supplied with a standard unvented cylinder, the following components are also supplied with a pre-plumbed cylinder:-

- Two Port Motorised Valve (3 per twin zone kit)
- PCB Wiring Centre
- Dual Cylinder Thermostat
- 6m Head Circulator pump
- Automatic bypass valve
- Manual air vent
- Sealed system filling loop
- Primary adaptor, comes with expansion valve and gauge - LOOSE
- Primary expansion vessel (120-170L capacity = 12L, 200-250L = 19L, 300L = 24L) - LOOSE
- Three Channel system programmer - LOOSE
- Digital room thermostat - LOOSE

Potable water connections

The potable (secondary) water connections are a mix of 22mm compression on components and 3/4" BSP onto the vessel, and are connected under the same manner as listed in the main installation manual. These connections include; cold mains to inlet control set, balanced cold supply from inlet control set, hot water draw off, secondary return connection (where fitted), expansion vessel, vessel bracket and fitting, and tundish discharge pipework.

Primary water connections

All primary pipework connections are 22mm compression with gland nut and olive at each connection point and require connection in the standard method.

Boiler flow:- Remove and discard the transit pipe under the circulating pump by releasing the outer of the pipe clamp and the gland nut to the pump isolation valve. Connect the boiler flow pipework directly into the pump isolation valve re-using the pipe clamp to provide support to both the pipework and the circulating pump.

Heating flow:- Connect from each relevant 2-port motorised valve the heating flow into the radiator circuit for the heating zone required.

Heating return:- The heating return pipework returns back into the pre-plumb cylinder pipework connecting to the 22mm connection on the right hand side of the unit adjacent to the installed cold feed pipework.

Boiler return:- The pipework connection from both the central heating and the hot water circuit is the lower right 22mm connection below the heating return. This connection requires piping directly back to the boiler.

Primary Expansion:- This pre-plumb unit is supplied with a manifold connector facilitating the heating expansion vessel, expansion discharge valve and pressure gauge. The assembly is usually installed in the pipework adjacent to the boiler appliance - see both the boiler manufacturer's requirements and the instructions provided with the components supplied. Check the vessel is charged to 1.5 bar on installation. Ensure the discharge pipe terminates at a point where the discharge of hot water is visible, yet does not cause any danger to people or to property.

Wiring requirements

Pre-plumb wiring requirements are as per the diagram at the back of these instructions.

The factory assembled pre-plumb wiring detail is shown to the lower section of the connector block complete with the plug in connector detail.

The upper section of the wiring to the connector block depicts connections to be created by the installer.

System filling & Commissioning

Once all plumbing and wiring is complete, the primary system may be filled and flushed in the proprietary manner. Before filling ensure all drain points and air valves etc. are fully closed. Fill via the filling loop provided, ensuring the 2 port valves and the circulating pump isolation valves are fully open.

Release all air from the pre-installed manual air vent installed at the highest point of the pre-plumb pipework and also any other high points in the system. The normal fill pressure is 1.0 bar to 1.5 bar - check both the boiler and radiator manufacturers' requirements. During filling ensure all plumbing connections, including factory made connections are water tight, prior to leaving the factory the effects of transit may cause some connections to subsequently leak upon filling, for which we can accept no responsibility for damage or inconvenience caused.

Once the system is full of water and devoid of air, turn on the boiler appliance and thermostats and heat both the hot water and the heating circuits. The recommended hot water storage temperature is 60°C. Adjust the manual bypass valve as per the manufacturer's instructions included. Check all components are functioning correctly and that there are no leaks present

Cylinder Connections

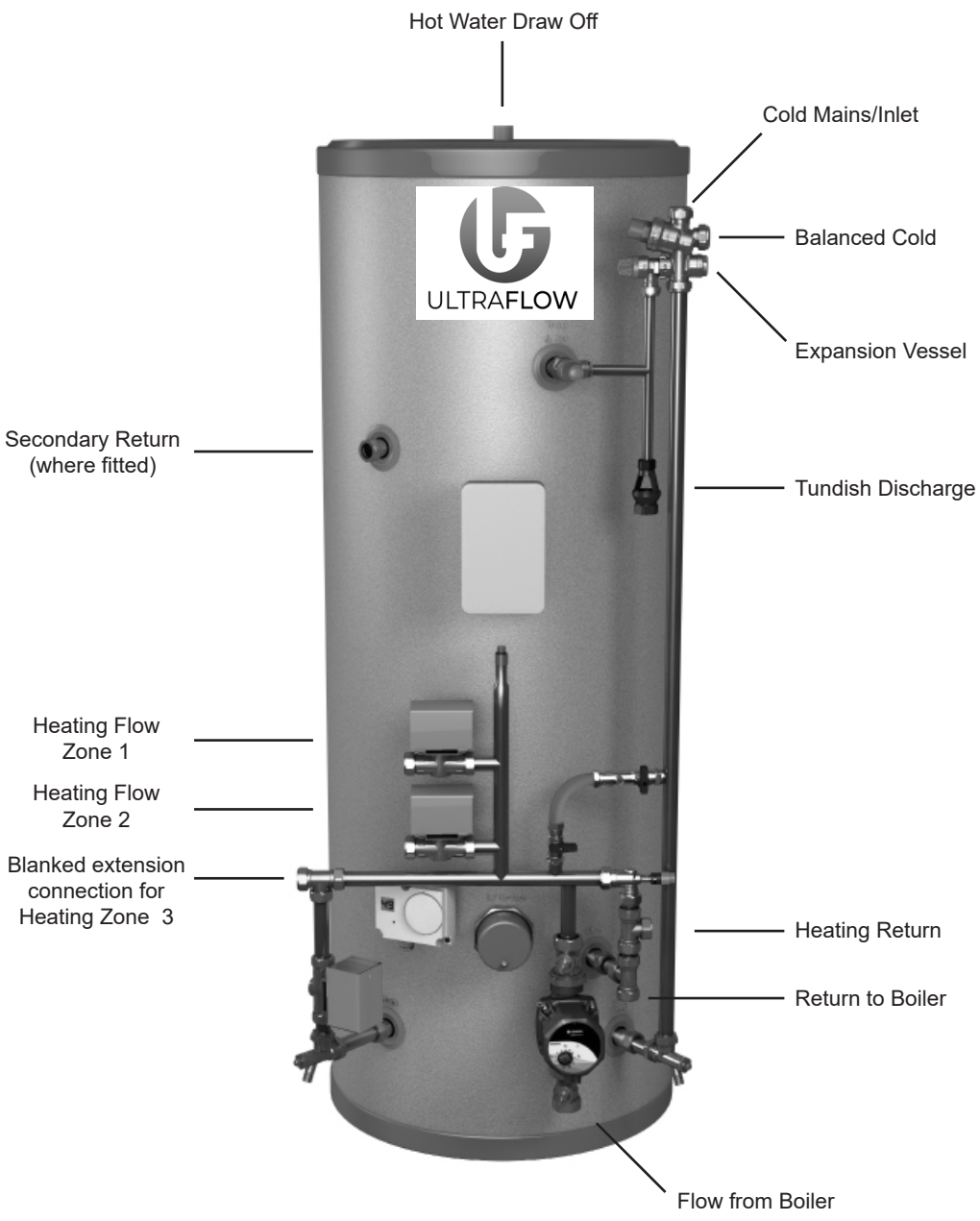

Twin Zone Cylinder depicted for example illustration purposes only

Twin Zone Wiring Requirements

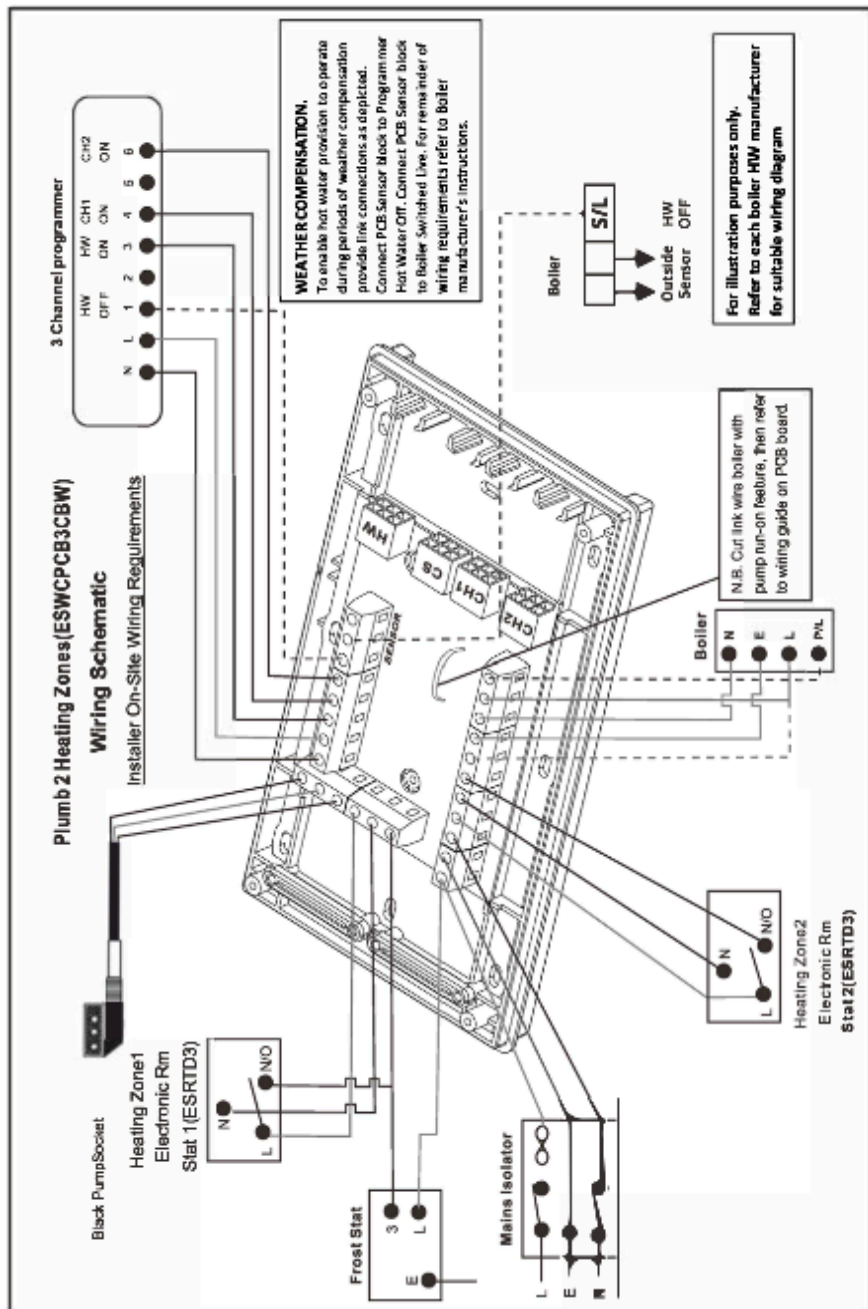

For clarity, a twin zone heating schematic is pictured. For single heating zone use, only connect CH1 connections, leaving CH2 unused.

Cylinder Connections

The following diagram details how to link the wiring centre to ESI's Wi-Fi SMART Controls.
(Not supplied as standard with Pre-Plumb Units)

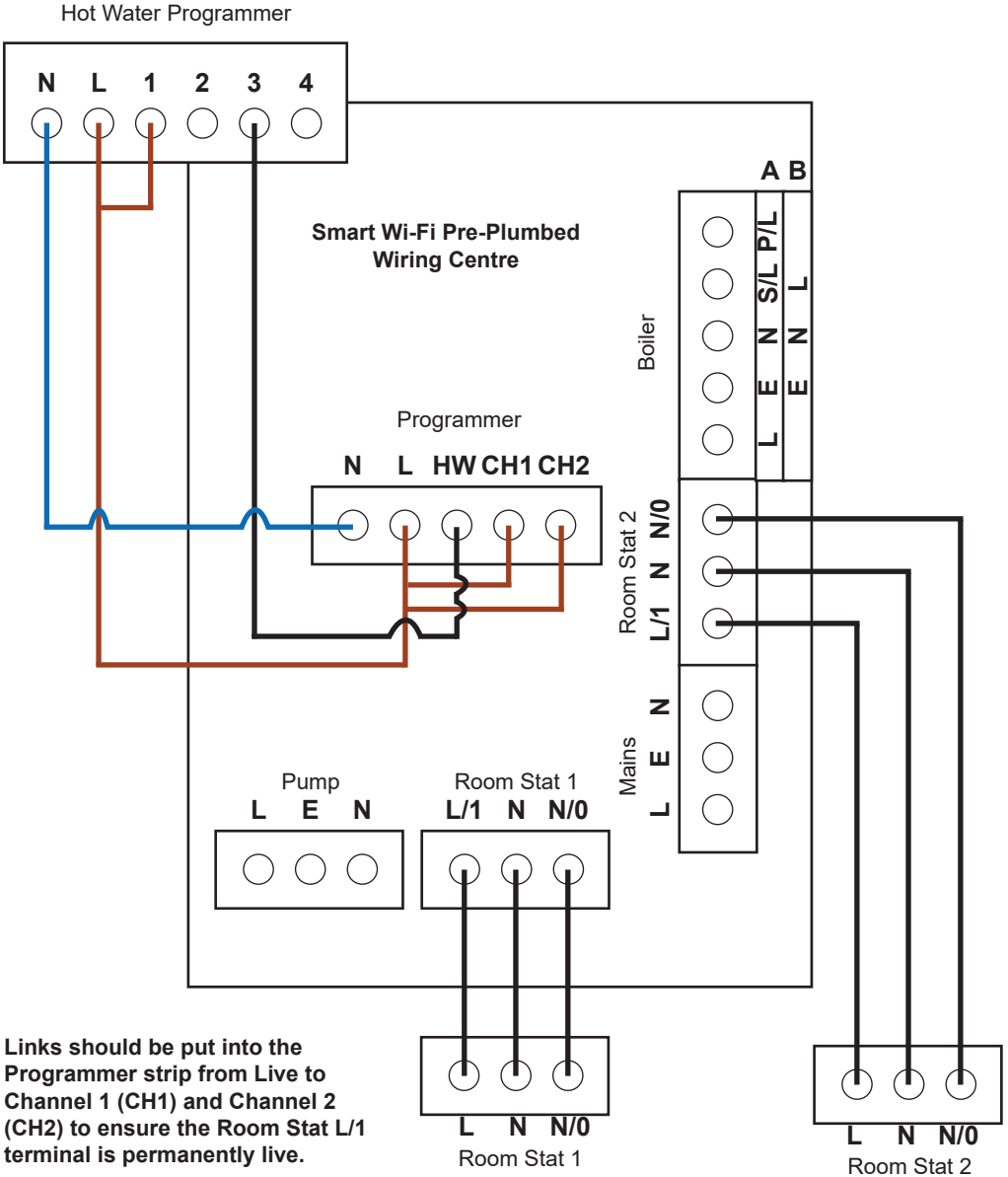

ESWPCB3CBW PCB Wiring Centre

User and Installation Instructions

PCB Wiring Centre

The ESI Controls PCB Wiring Centres, using our plug in system, really simplify and speed up installation and utilise our plug in Zone Valves.

The ESWPCB3CBW is for Two Heating Zones and Hot Water. With models to suit the new ESI Controls Electronic Dual Cylinder Thermostat, the ESCTDEPW.

Installation

Always isolate the AC mains before installing the wiring centre. Plug the system components to the correct terminals.

PCB Wiring Centre	
Protection Rating	IP20
Power Supply	230VAC 50-60Hz
Maximum PCB Current	Fused at 3 amp
Operating Temperature Range	0°C to 45°C
Fixing	4 fixing holes
Dimensions	L196 x W142 x D40 (mm)
Complies With:	EC Directive 2006/95/EC, EMC (89/336 & 92/32 EEC) BS EN 60730-1:2000 BS EN 60730-2-9:2002. LVD (73/23/EEC) (93/68/EEC) BS EN 60730-1:2000 BS EN 60730-2-9:2000)

WARNING!

Interference with sealed parts renders the guarantee void. Always isolate the ac mains supply before removing or fitting the product. This accessory must be fitted by a competent person, and installation must comply with the guidance provided in the current editions of bs7671 (ie wiring regulations) and part 'p' of the building regulations.

In the interests of continuous product improvement we reserve the right to alter designs, specifications and materials without prior notice and cannot accept liability for errors.

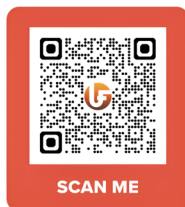

Ultraflow UK Limited

103 Lockfield Avenue Enfield EN3 7PY

Tel: **020 8443 5111** Email: sales@ultraflowuk.com