



ULTRAFLOW

Direct Buffer Store

INSTALLATION MANUAL V1 2022

DIRECT BUFFER STORE TO BE INSTALLED IN CONJUNCTION
WITH A HEAT PUMP

IMPORTANT

This range of direct buffer stores should only be installed as per these instructions by a competent & certified heating installer. By installing this product you agree to be bound by the purchasing and warranty terms and conditions found in this manual and on our website.



INTRODUCTION

This UK manufactured product is made from Duplex stainless steel, providing durability and long-lasting resistance against corrosion. It is highly insulated with environmentally friendly foam, and enclosed in a rust resistant outer steel case.

This buffer store is designed to be installed in conjunction with a heat pump, acting as an interface between the heat pump and other areas of the primary system. A buffer store will act as a load leveller for the heat pump reducing operating peaks and cycling which improves the smooth running of the appliance. Your heat pump provider will be able to advise on the full benefits and sizing preferences for a buffer store to operate effectively in conjunction with their specific heat pump.

Our direct buffer stores are available in capacities of 50 - 600 litres.

STORAGE AND HANDLING

Care must be taken when handling the product. Seek assistance when moving the product as required, and follow safe working practices and lifting techniques to avoid injury or product damage. Before installation, the direct buffer store must be stored upright in its original packaging, on a secure, level surface within a dry and frost-free environment.

GENERAL INSTALLATION REQUIREMENTS

The direct buffer store must be installed, commissioned and maintained by a competent installer holding suitable qualifications, and/or being a member of a competent persons' scheme. Once the unit is installed and commissioned, the user must be provided an explanation of the operation of the direct buffer store and any key safety components. In addition, the end user must be given this installation manual for future reference.

SITING THE UNIT

This product must be installed vertically on a flat base that is capable of supporting the maximum-fill weight of the direct buffer store. The minimum recommended cupboard size is 650mm square as the product diameter can vary (capacity and configuration dependant) between 475mm to 580mm. Ensure there is access to all direct buffer store safety controls / immersion heaters and for future valve maintenance or replacement during service. Therefore, please ensure all connections are outward facing towards a door or similar opening for this purpose. Areas subject to freezing should be avoided. If the cylinder is sited outside of a heated area of the dwelling, such as a garage or outbuilding, ensure the provision of adequate frost protection, such as insulation of exposed pipework. Pipe lengths must be kept to a minimum to ensure minimal losses.

MAKING A CONNECTION

The pipework connections on this direct buffer store are 1" F BSP and require 1" M x 28mm compression fitting or 1" M x 22mm compression fitting for connection to 28mm and 22mm copper tube respectively. Do not connect directly to the cylinder with composite tube. Use a WRAS approved thread sealant on the BSP threads of the connection. Connect 28mm / 22mm tube using the nut and olive. Use of a WRAS approved paste is recommended for a watertight seal on the olive.

Thermostat pockets are provided for temperature sensors and high limit control where required.

SYSTEM DESIGN

The direct buffer store may be installed in an open vented or sealed system format with a maximum primary pressure of 3.0 bar. The store must have unhindered pipework access to both the pressure relief valve and the expansion vessel. When sizing the expansion vessel the whole contents of the primary system including the direct buffer store must be included. The system guidance in the manual shows two popular alternative methods of linking the direct buffer store into a system. Your heat pump provider will, within their manual, provide detail of their preferred options for installation layout and these should always be the chosen option.

DRAWINGS

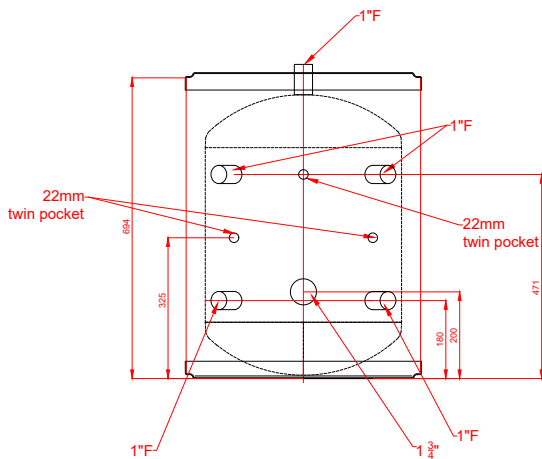
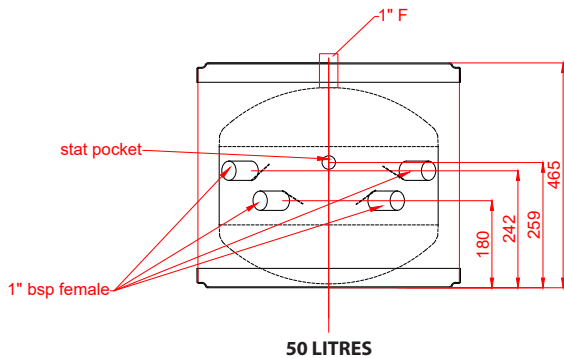

DRAWINGS (CONTINUED)

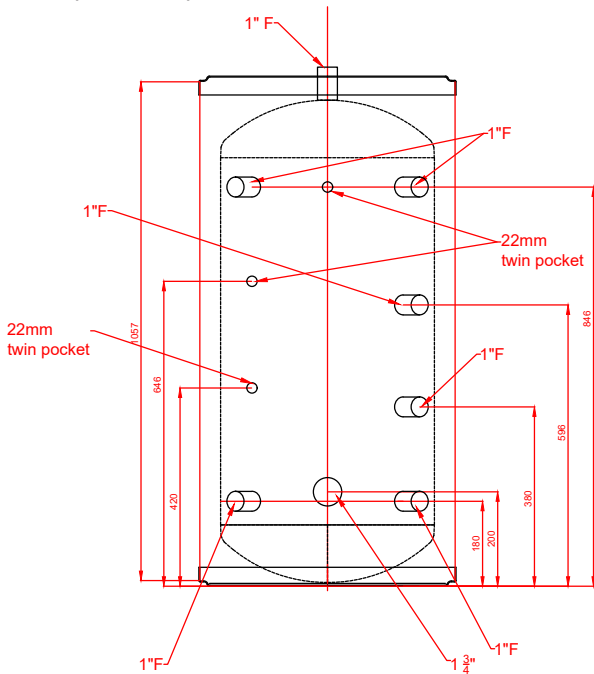

150 LITRES

SCHEMATICS

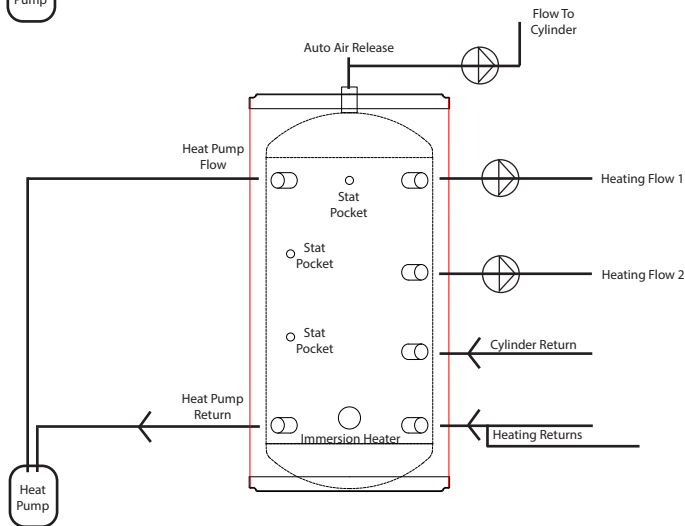
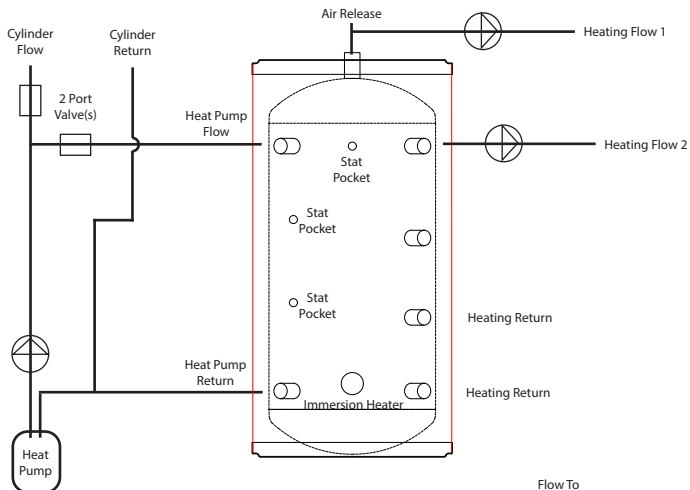

GUARANTEE AND EXEMPTIONS

The direct buffer store carries a 25-year guarantee against faulty materials or manufacturing, based upon the following conditions:

- Correct installation as per this document and all relevant standards, regulations, and codes of practice in force at the time.
- The Benchmark Commissioning Checklist has been completed
- The unit has been serviced annually.
- The product has not been modified in any way, other than by us.
- There has not been any misuse, tampering, or neglect of the cylinder.
- It has only been used for the storage of potable water
- It has not been subjected to frost damage
- The system is fed from a public mains water supply
- Storage temperatures have not exceeded 65°C
- Installations made only in the United Kingdom.
- The water chemistry used in the system is found to be above the maximum allowances.
- Units are not installed with uncontrollable heat sources (e.g. wood burning stoves)
- For commercial or heavy-duty installations where constant usage and reheating is required, titanium immersion heaters must be fitted to comply with the warranty
- The guarantee period starts from the date of purchase.
- The extended guarantee is not transferable and rests with the original householder.

EXCLUSIONS

- The effect of scale build-up on the unit or its components
- Any labour charges associated with replacing the unit or its parts
- Any consequential losses caused by the failure or malfunction of the unit.

Note: Invoices for servicing may be requested to prove that the unit has been serviced annually. All the components fitted to/or supplied with the cylinder carry a 2-year guarantee. The guarantee starts when the cylinder is first filled.

CLAIMS

On the rare occasion of a fault occurring, we will only consider sensible claims that are submitted in full at the time when the faulty part/unit is returned to us.

We will not cover any installer claims for excessive travelling where the installer has accepted a job more than 30 miles from their base of operations.

Removal costs cannot be recovered for the collection of a faulty unit from a difficult to reach area or where cylinder access has been restricted (as per this manual guidance.)

Claims will not be accepted for units that have not been installed in accordance with this manual.

PROBLEM GUIDANCE

When a problem arises, your first point of contact is the plumber who fitted the unit (in the first year), followed by the plumber who carries out the annual servicing of your unit for you.

If your cylinder begins to leak, we will supply you with a new one. To prevent fraud, we request an up-front payment in this case while we establish the cause of the fault. The original unit must be returned to us for inspection along with a copy of your service record and commissioning checklist. Your upfront payment will be refunded as soon as it is confirmed that the cylinder has failed within the terms of our warranty.

If a component part fails within the two-year guarantee, we will send you a new one with an upfront charge. Your credit card details may be required to prevent fraud. We ask you to post the faulty part back to us by recorded delivery within a month. A refund will be issued once the part has been tested and proven to be at fault.

APPENDIX - WATER CHEMISTRY

This water heater is manufactured to suit the water conditions of most public reticulated water supplies. However, there are some known water chemistries which can have detrimental effects on the cylinder. If you are unsure of your water chemistry, you may be able to obtain the relevant water chemistry information from your local water supply authority.

*Our warranty will not apply where water stored in the storage cylinder exceeds at any time any of the following levels: - TOTAL HARDNESS 200mg/L, TOTAL DISSOLVED SOLIDS 600mg/L

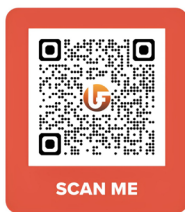

Ultraflow UK Limited

103 Lockfield Avenue Enfield EN3 7PY

Tel: **020 8443 5111** Email: **sales@ultraflowuk.com**